

WISeNET

4K VIDEO SECURITY SYSTEM

Quick Start Guide

Troubleshooting

If you are experiencing video loss, verify that all cables are properly and securely connected to the DVR.

- Check your Network Connection
- Check your Username and Password
- Restart the DVR if you have trouble connecting.
 - ✓ Main Menu > Shutdown > Enter Username & Password > Click "Reboot"
 - ✓ To reset your DVR to factory settings, refer to the User manual.



For more information about your product, please download the User Manual from "wisenetlife.com".

DVR Setup

KIT Model

SDH-B94047BF/SDH-C94087BF/SDH-E95127BF

DVR Model

SDR-94307/SDR-95307

- 8CH DVR

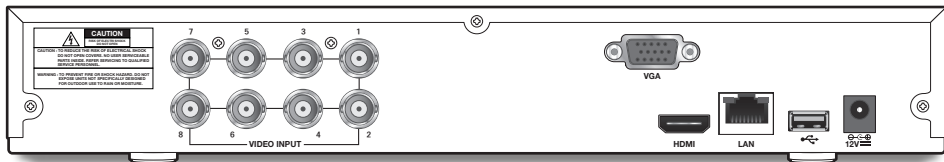

- 16CH DVR

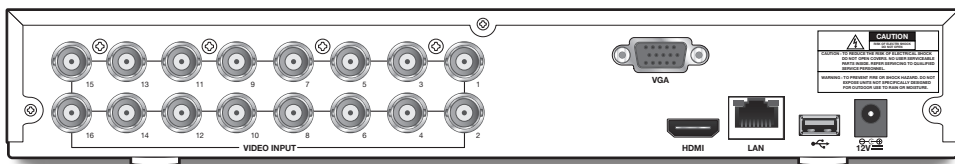











DVR Setup









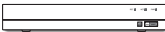
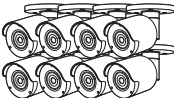

Package Contents

- ✓ The appearance of the components may differ from the image shown.
- ✓ Accessory category and quantity may differ depending on sales region.
- ✓ The administrator is recommended to store the remote control carefully in order to initialize it if the password is lost.

• SDH-B94047BF

			
SDR-94307	SDC-99447BF	60ft camera cable	Ethernet cable
			
HDMI Cable	Remote Control / Remote Control Battery (AAA x 2)	Mouse	Power splitter
			
Screw x 3EA (per Camera) / Anchor x 3EA (per Camera)	Power adaptor for DVR / Power adaptor for 4 Cameras	Printed Material	

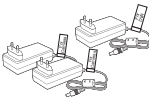
• SDH-C94087BF

			
SDR-94307	SDC-99447BF	60ft camera cable	Ethernet cable
			
HDMI Cable	Remote Control / Remote Control Battery (AAA x 2)	Mouse	Power splitter (2PCS)
			
Screw x 3EA (per Camera) / Anchor x 3EA (per Camera)	Power adaptor for DVR / Power adaptor for 4 Cameras(2PCS)	Printed Material	

• SDH-E95127BF

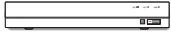

SDR-95307

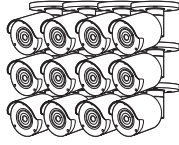

SDC-99447BF

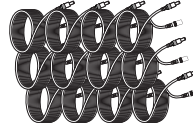

60ft camera cable



Ethernet cable



HDMI Cable



Remote Control /
Remote Control Battery
(AAA x 2)



Mouse



Power splitter (2PCS)



Screw x 3EA (per Camera) /
Anchor x 3EA (per Camera)

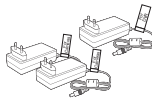

Power adaptor for DVR /
Power adaptor for 8
Cameras(2PCS)

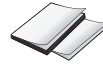

Printed Material

DVR Setup

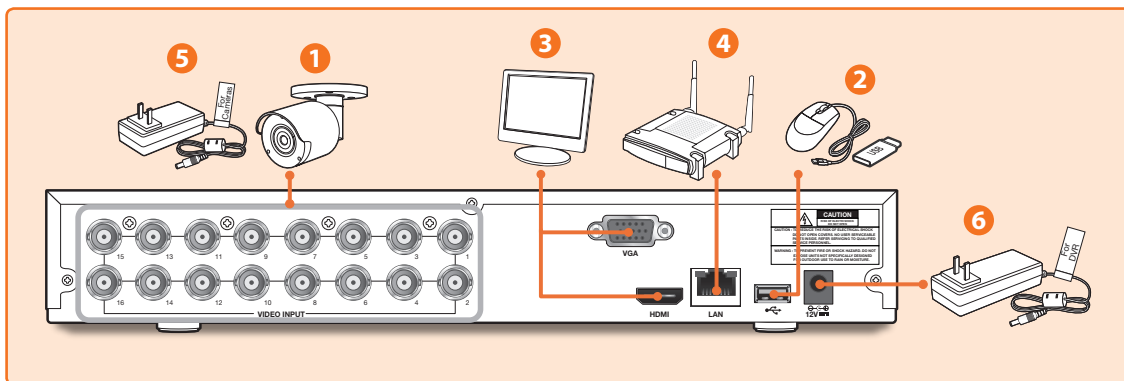

1. Connect the camera's video input (yellow) and power supply (red) connectors to the BNC extension cables. Then connect the BNC video input (yellow) to the video input port on the rear panel. (Repeat Step 1 for the remaining cameras.)

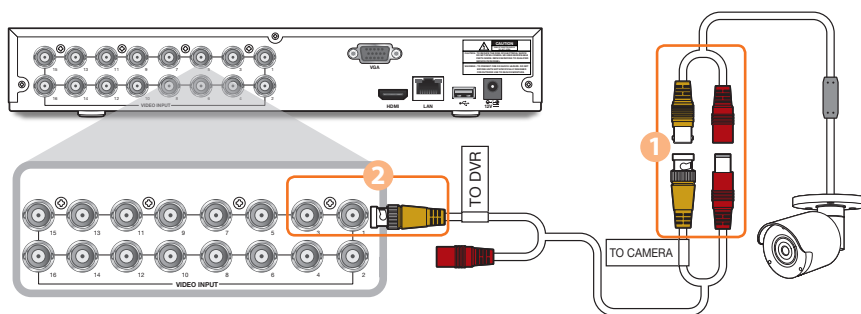

2. Connect the mouse to the USB Port on the front or back panel of the DVR.

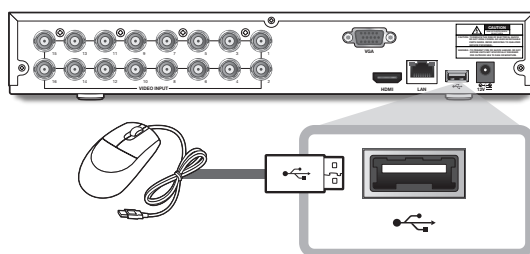

3. Depending on the monitor port, connect the HDMI or VGA cable from your monitor to the HDMI or VGA Port on the rear panel.

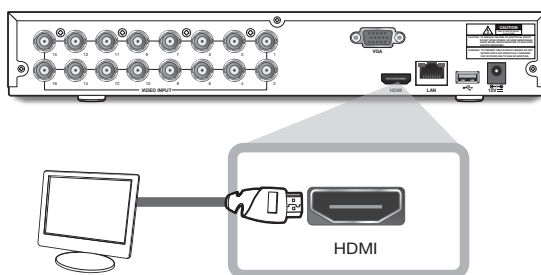

4. Connect one end of the Ethernet cable into your router's LAN port, and the other end of the cable to the Ethernet port on the rear panel.

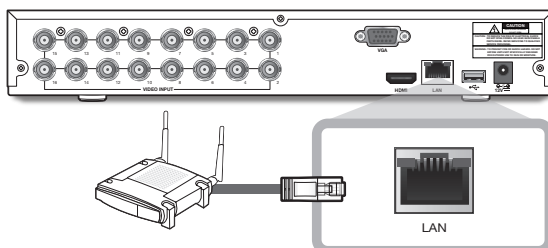

5. Connect the camera's power supply (red) to the power splitter. Then connect the other end of the power splitter to the power adapter for Cameras and plug in the adapter to a wall outlet. (Repeat Step 5 to connect the cameras to the second set of power splitter and power adapter.)

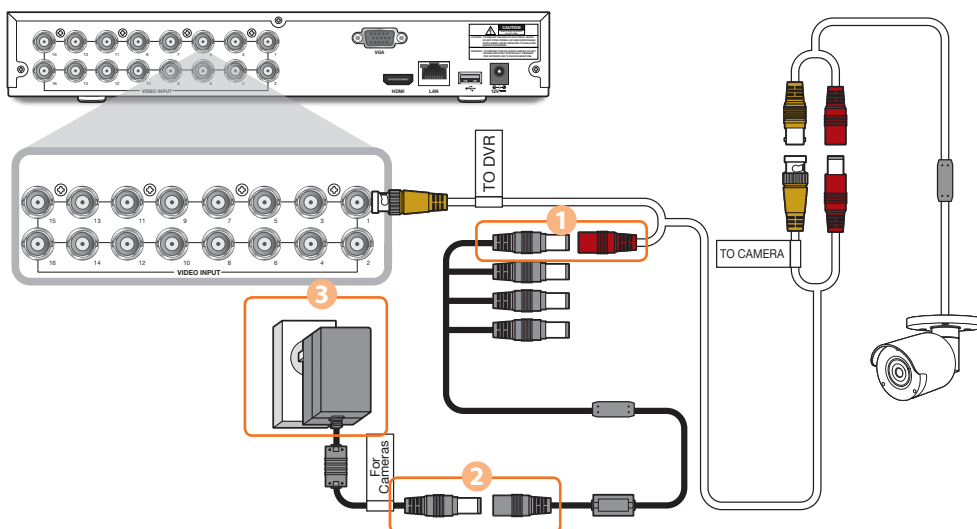

6. Connect the power adapter for DVR to the DC 12V port on the rear panel and the power plug into a wall outlet. The DVR will automatically power on and the startup wizard will appear on your monitor.

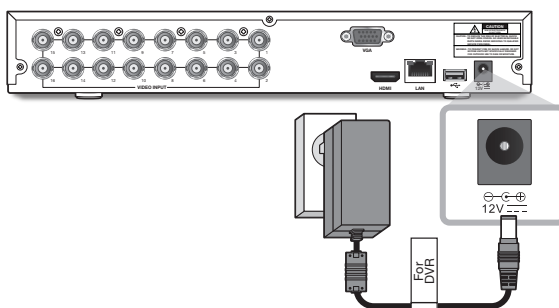

Startup Wizard Guide

Change your password on a regular basis.

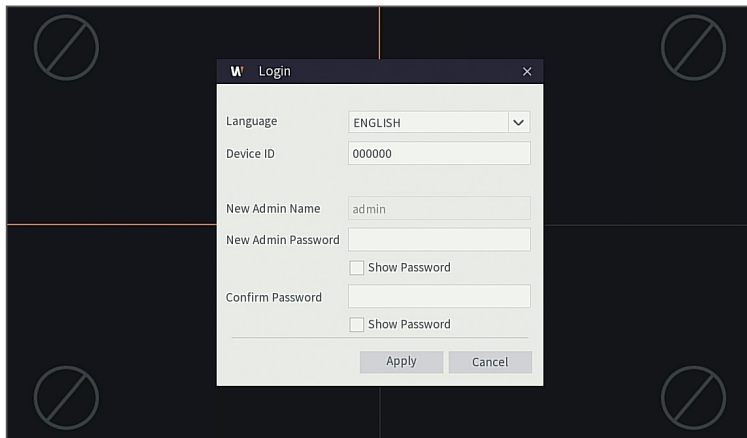

- ✓ Please create a user name and password for your device. Password **MUST** be 8~13 characters long. When password is 8~9 characters long, it should be with at least a combination of letters, digits and special symbols. If it is 10~13 characters long, it should be with at least a combination of two types of characters. 4 or more contiguous or repeated characters or key arrangement are prohibited, for example 1111, 1234, abcd, qwerty.

1. After DVR startup is completed, the startup wizard will be displayed. Click "Start Wizard".

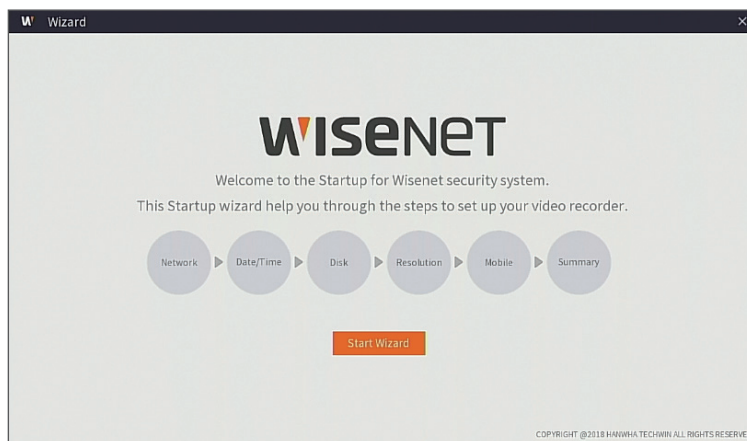

2. Network

In DHCP mode the router will automatically assign an IP address to DVR.

If the DVR fails to obtain an IP address, refer to the DVR Router Guide. If the problem still cannot be resolved, contact technical support.

The screenshot shows the 'Wizard' configuration window, Step 1: Network. The window is divided into a left sidebar with steps 1 through 6, and a main content area. The 'Local Connection' section is active, showing DHCP settings. The 'DNS' section shows DNS1 and DNS2 settings. The 'Port' section shows Web Port, Client Port, and Quick Connect settings. The 'PPPoE' section shows Enable PPPoE, User, and Password settings. The 'Next' button is highlighted.

Section	Parameter	Value
Local Connection	DHCP	<input checked="" type="checkbox"/>
	IP Address	192.168.001.100
	Subnet Mask	255.255.255.000
	Gateway	192.168.001.001
DNS	DNS1	168.126.063.001
	DNS2	008.008.008.008
Port	Web Port	00080
	Client Port	09000
	Quick Connect	<input type="checkbox"/>
PPPoE	Enable PPPoE	<input type="checkbox"/>
	User	
	Password	<input type="password"/> <input type="checkbox"/> Show Password

3. Date/Time

Set the date, time, NTP, DST.

The screenshot shows the 'Wizard' configuration window, Step 2: Date/Time. The window is divided into a left sidebar with steps 1 through 6, and a main content area. The 'Date and Time' section is active, showing Date, Time, Date Format, Time Format, and Time Zone settings. The 'NTP' section shows Enable NTP and Server Address settings. The 'DST' section shows Enable DST, Time Offset, DST Mode, Start Time, and End Time settings. The 'Next' button is highlighted.

Section	Parameter	Value
Date and Time	Date	09/18/2019
	Time	10:13:24
	Date Format	MM/DD/YY
	Time Format	24Hour
	Time Zone	GMT
NTP	Enable NTP	<input type="checkbox"/>
	Server Address	pool.ntp.org
DST	Enable DST	<input type="checkbox"/>
	Time Offset	1Hour
	DST Mode	Week
	Start Time	Mar. The 2nd Sun. 02:00:00
	End Time	Nov. The 1st Sun. 02:00:00

Startup Wizard Guide

4. Disk

New hard drive(s) connected must be formatted before use. Upon connection, it will indicate to format new hard drive. Click on "Select" to select the unformatted hard drive. Click on "Format HDD" to pop up the user login window and enter the password to log in. A notice window will indicate "Entire data will be erased. do you want to continue?". Click "OK" to format the disk. When the progress bar is complete, the formatting process is completed.

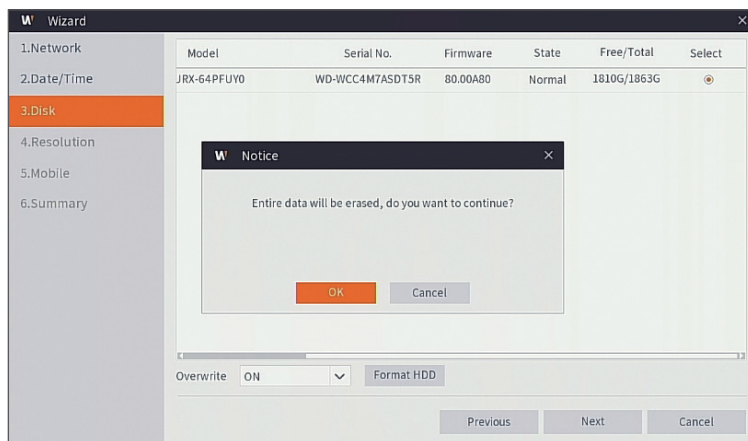

5. Resolution

Select the resolution for the VGA output or HDMI output of your monitor.

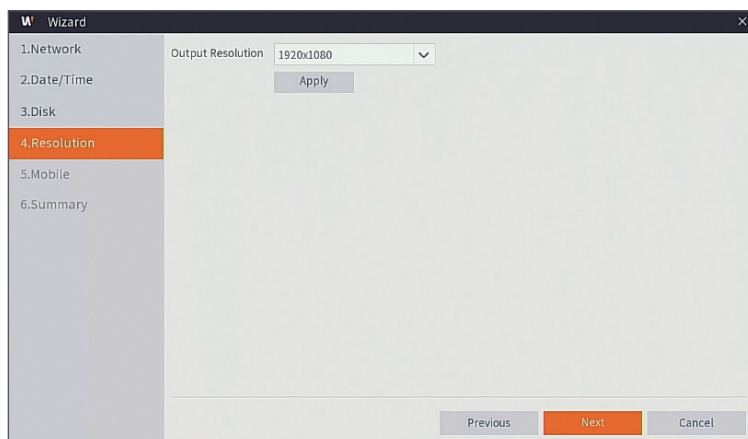

6. Mobile

If you scan a QR code using WisenetLife App, the device ID displayed in the DVR will be automatically reflected in the Mobile Viewer ID, and you can use the Mobile Viewer immediately by entering the password of the DVR.

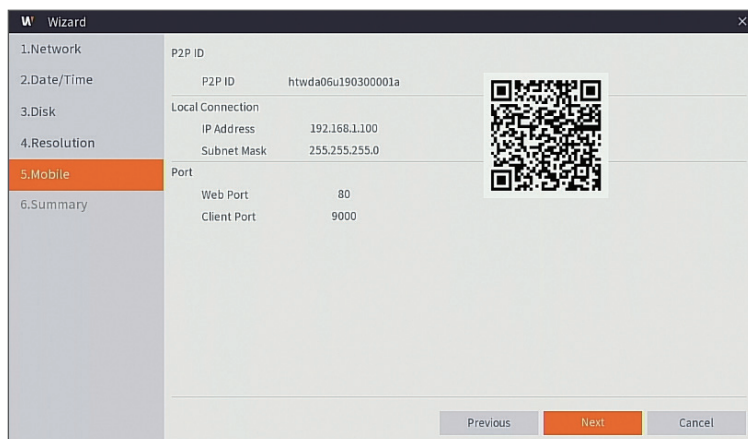

7. Summary

Shows system and network status of DVR.

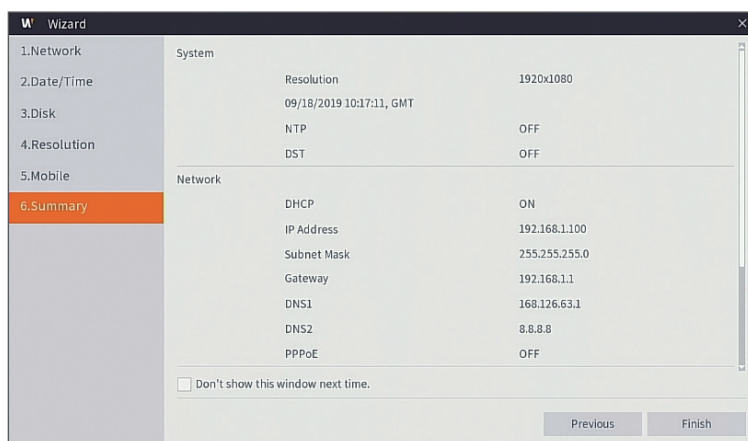

8. Click on "Finish" to finish setting of startup wizard.

- ✓ You can click on "Don't show this window next time" if you do not wish to have the wizard setting to appear next time.

Main Interface

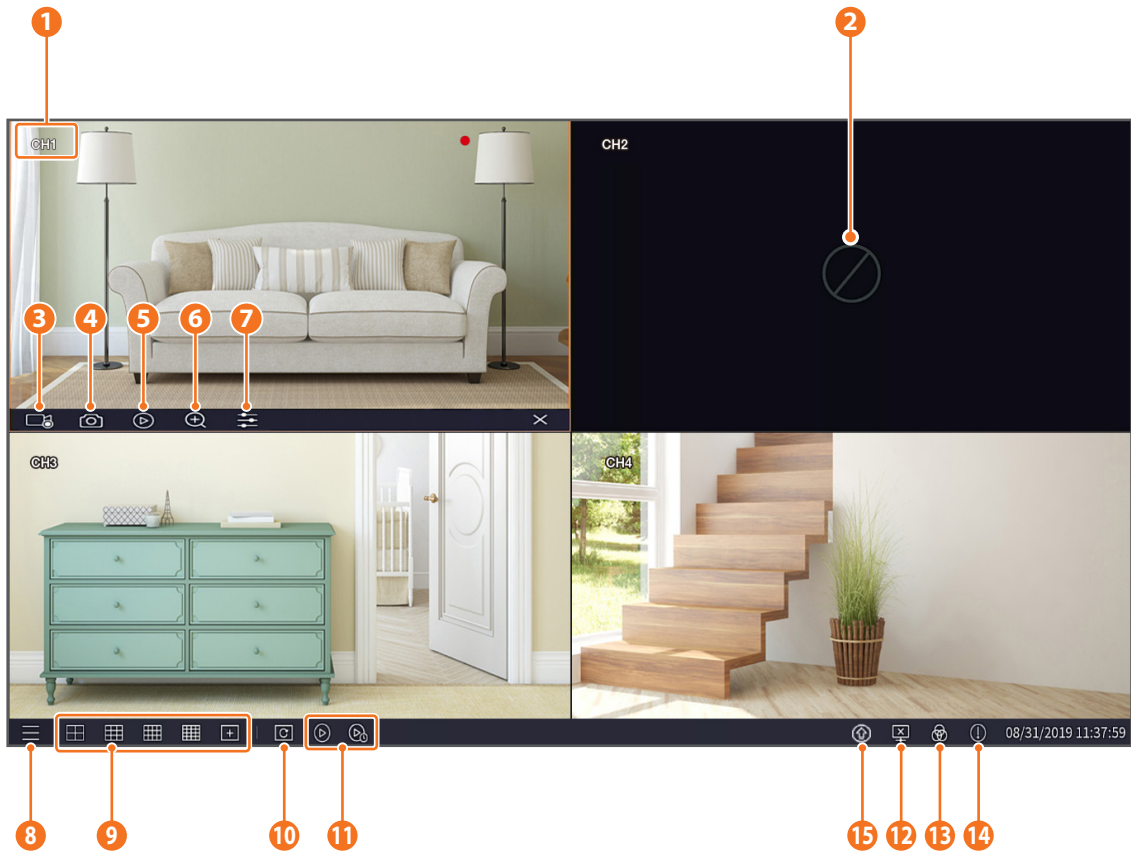

The video recording marks are shown below

- : means common Recording.
- 👤 : means Motion detection recording.

1	Channel Name	Display channel name
2	Video Loss	Camera is off-line
3	Manual Recording	Enable or disable manual recording
4	Manual Capture	Make a snapshot of current video
5	Instant Playback	Playback of the last five minutes of the video

6	Zoom	Hold and drag mouse cursor to select a frame of current video to zoom in
7	Color Setting	Set hue, brightness, contrast and saturation of current channel
8	Main Menu	Access the main menu
9	4-Channel Layout	Display 4 channels of video
	9-Channel Layout	Display 9 channels of video
	12-Channel Layout	Display 12 channels of video
	16-Channel Layout	Display 16 channels of video
	More Layout	Display 6/8/10/13/14 channels of video
10	Auto SEQ	Press this button to switch the screen mode in sequence
11	Play	Replay video recorded
12	Connection state	Display the network connection status
		 connect fail : Not connected WAN.
		 not connect : Not connected physically.
		 connect success : connected WAN.
13	Manual mode	Set manual recording mode
14	System	System Information
15	Firmware upgrade	Once a new firmware is uploaded, the Download icon will appear.

Remote Viewing & Cloud Service

Once you've set up your system, you can access to your cameras from anywhere, anytime using Wisenet Life Cloud service.

- ✓ The appearance of the viewer may differ from the image shown.

[With your PC]

1. OS and browser environment

- OS requirements:
 - Windows 7 or higher
 - Mac OS 10.12 or higher
- Browser requirements
 - Please use the latest version of the Chrome (Windows OS), or Safari (Mac OS) browsers.

2. Start Wisenet Life monitoring & Cloud Service

- 1) Open your web browser and go to cloud.wisenetlife.com
- 2) Click the "Create Account" button to proceed with signing up.
You will need to verify your registered e-mail account to complete the signup.
If you already have a Wisenet Life account, log in and register your product.
- 3) After logging in, proceed with device registration.
- 4) Enter the serial number on the bottom of the device's QR code as the QR code ID.
- 5) Enter your Device Password of your DVR.
 - You can only log in with an admin account.
- 6) Create a name for your DVR and complete the registration.

The screenshot shows a web browser window with the URL cloud.wisenetlife.com/#/device/registration. The page is titled "Device registration" and includes the following content:

- A header with the Wisenet Life logo.
- A central form titled "Device registration" with an image of a camera above it. The form contains:
 - A note: "This page is for All-in-One device registration. Supported model: SDH-B040878F / SDH-C040878F / SDH-C032087F / SDH-C051278F / SDH-B040478F / SDH-C040878E / SDH-B730478W / SDH-C051278F. Before registering, make sure that the device is connected to the network."
 - A field for "QR Code ID" with a QR code icon.
 - A field for "Device Password" with a note: "Please enter the Admin password of the device."
 - A field for "Nickname" with a note: "Please create a name for the device. (e.g. living_room)".
 - A "Registration" button.
- A section for "Smart Home Camera" with a small image of a camera and the text: "Can be registered to Smartcam + mobile app."
- A footer with links for "Wisenet life", "Contact Us", "Terms Of Use", "Privacy policy", and "Company policy", and a copyright notice: "Copyright © HANMIRA TECHNIK CO., LTD. 2018. All rights reserved."

[With Mobile Devices]

1. Recommended Mobile OS version
 - Android: v6.0 or higher
 - iOS: v10.0 or higher
- ※ Some functions may not work properly depending on the manufacturer of the mobile device
2. Start Wisenet Life monitoring & Cloud Service
 - 1) Open Google Play or the App Store and download the free Wisenet Life app.
 - 2) Once installed, open the Wisenet Life app.
 - 3) Click the "Sign Up" button to proceed with signing up.
You will need to verify your registered e-mail account to complete the signup.
If you already have a Wisenet Life account, log in and register your product.
 - 4) After logging in, tap or click [+] to add a new device.
 - 5) Scan QR code
 - 6) Enter your Device Password of your DVR.
 - You can only log in with an admin account.
 - 7) Create a name for your DVR and complete the registration.

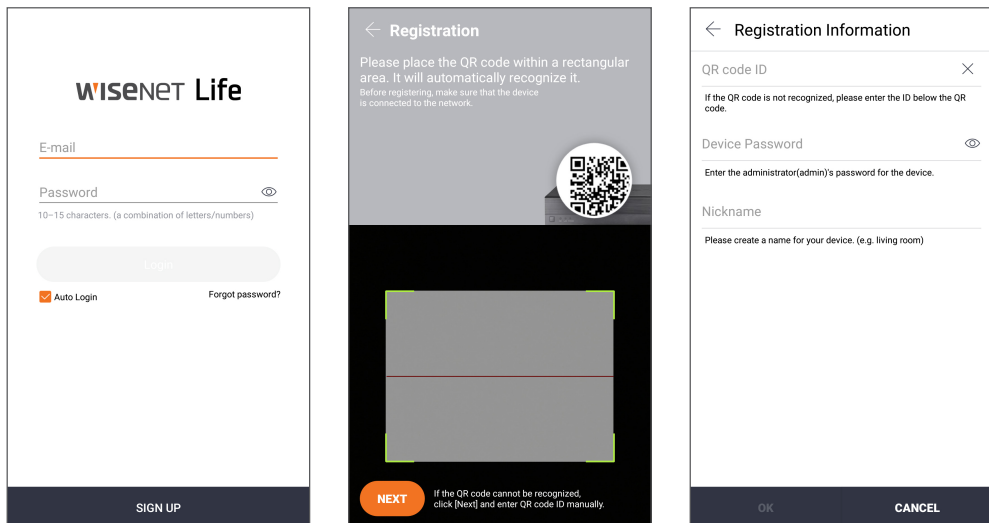

[Works with the Google Assistant]

Wisenet video security system is compatible with Google assistant and chromecast.

For more details, please visit www.wisenetlife.com

Remote Viewing & Cloud Service

User Interface

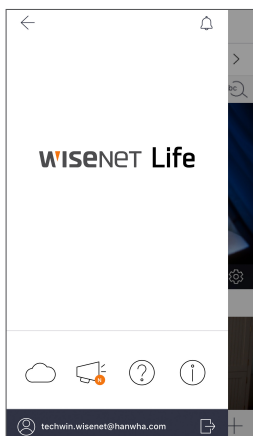
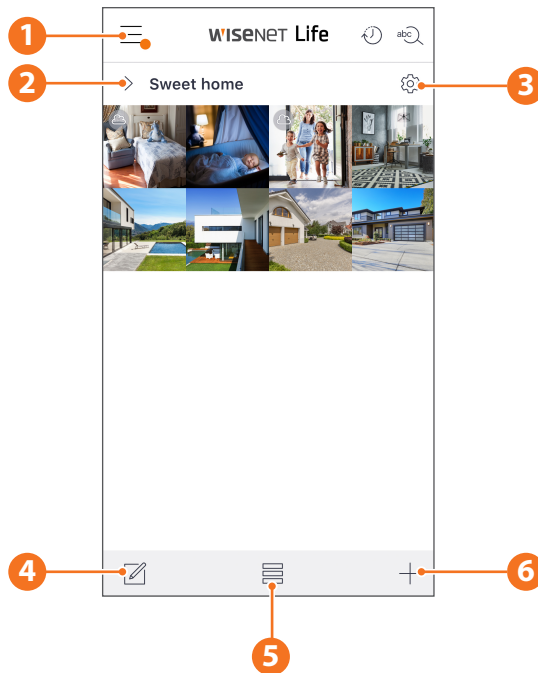

- 1 Main Menu**
Find the Information about your plan and notice and turn on/off your alert from the app



- 2 Device name**
You can check the live and event images of the device.
- The split screen configuration differs depending on the OS type.

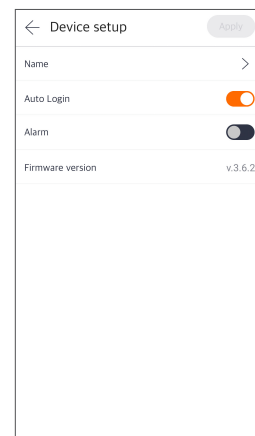

- 3 Device Setup**
You can change the settings of the device.

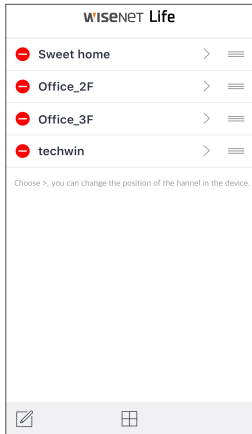

- 4 List Editor**
You can change the display position of the device.

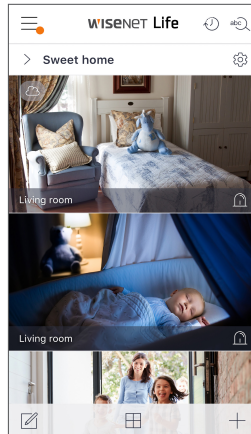

- 5 View mode**
View mode can be changed.

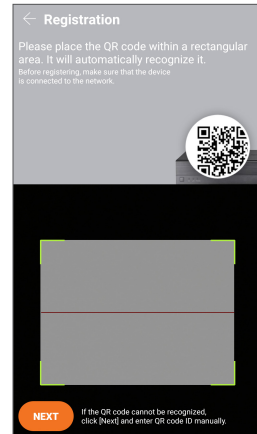

- 6 Add Device**
New devices can be added.

App Interface

Live & Playback

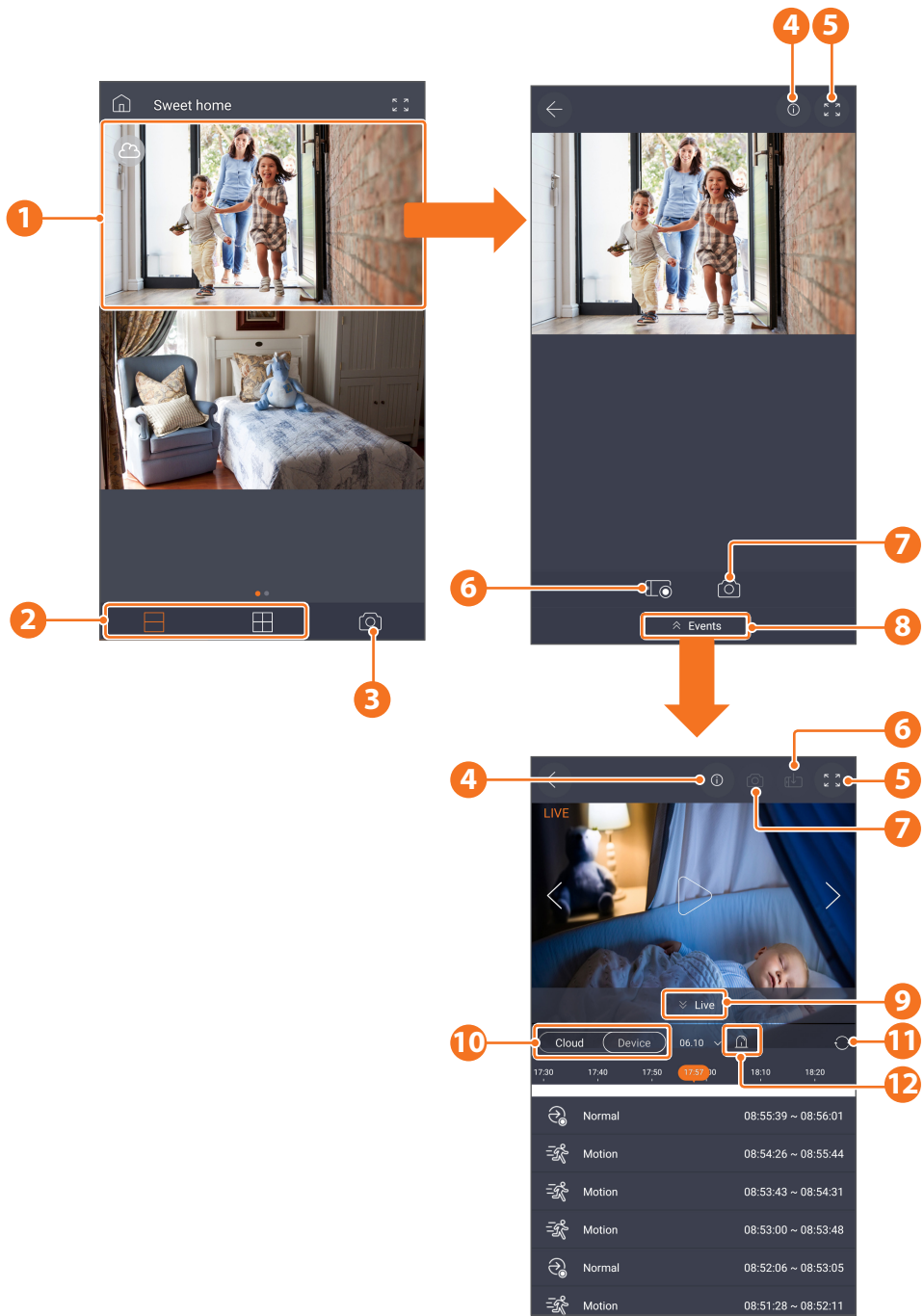

-
- 1 Go into single view mode
 - 2 2 or 4 Channel Split-Screen view
 - 3 Multi channel image capture
 - 4 UI guide
 - 5 Change to full screen mode
 - 6 Manual record and save
 - 7 Image capture
 - 8 Go into Event list page
 - 9 Go back to live page
 - 10 Select storage location
 - 11 Refresh the event list
- Event type
- 12
 - Cloud : Motion
 - Device : All Events/Motion
-

Camera Installation Template

To make camera installation easier, you can tear off this page and adhere it to the place you would like to install your cameras.

TEMPLATE

This template is used to install the camera on the wall

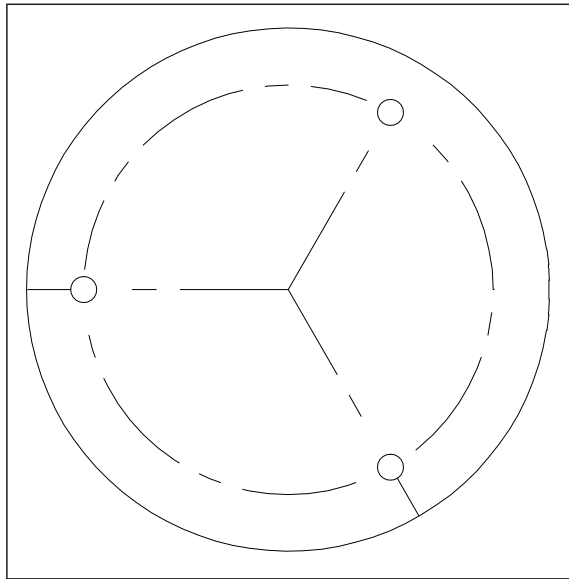

CAMERA FRONT



wISeNET